

Total No. of Questions :10]

SEAT No. :

P3670

[Total No. of Pages :4

[4959] - 1032

B.E. (Mech.)

CAD - CAM AND AUTOMATION
(2012 Course) (End Sem.) (Semester - I)

Time : 2½ Hours]

[Max. Marks :70

Instructions to the candidates:

- 1) *Answer in one answer books.*
- 2) *Answer Q1 or Q2, Q3 or Q4, Q5 or Q6, Q7 or Q8, Q9 or Q10.*
- 3) *Neat diagrams must be drawn wherever necessary.*
- 4) *Figures to the right side indicate full marks.*
- 5) *Use of Calculator is allowed.*
- 6) *Assume suitable data, if necessary.*

- Q1)** a) A Line PQ has coordinates P (5, 5) and Q (5, 105). Find the new coordinates of line if line is transformed to make it horizontal, keeping point P intact. [6]
- b) Compare Hermit cubic spline, Bezier curve and B - Spline curve. [6]

OR

- Q2)** a) Write a short note on Constructive Solid Geometry (CSG) technique. [4]
- b) For the loading shown in fig. 1, find nodal displacements, elemental stresses and support reaction. [8]

Geometrical information: Cross section area = 225 mm² and Length = 300 mm.

Material Properties: E = 80,000 N/mm².

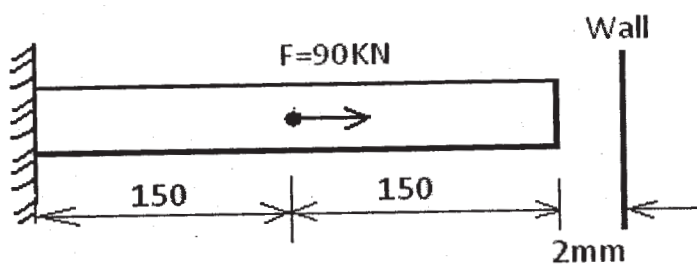

Fig.1

P.T.O.

- Q3)** a) Write a short note on Concatenated Transformation with examples. [4]
 b) Derive a relation between Local coordinate and Global coordinate systems in FEM. [4]

OR

- Q4)** a) Compare Solid Modeling with Wire - frame Modeling. [4]
 b) Explain Direct stiffness method to compute Element Stiffness Matrix of 1 - D element. [4]

- Q5)** a) Write a short notes with neat sketch on following: [8]

- i) Direct Numerical Control (DNC) system.
 ii) Tool radius and length compensation in milling.

- b) Write a manual part program for milling and drilling the machine part as shown in fig.2, using G and M codes. Assume suitable data for speed, feeds

- Thickness of plate is 20mm. Use *cutter radius compensation* for milling.
- Use *Peck - drill* cycle for drilling at (0, 0): Diameter 10 mm and Depth 15 mm. [10]

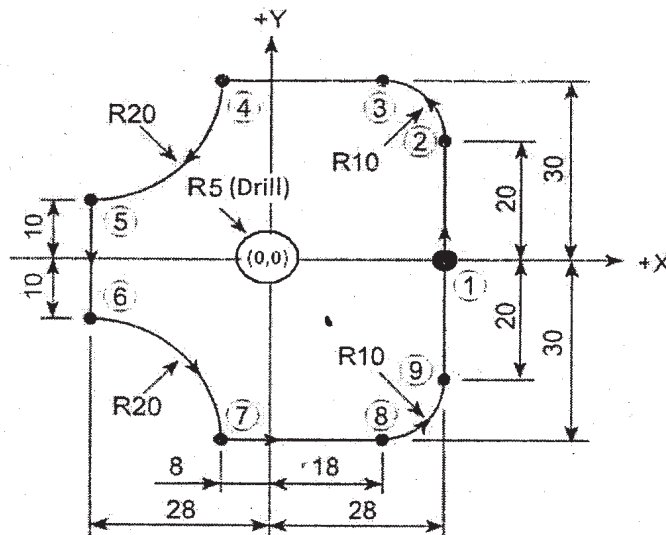

Fig.2 (All dimensions are in mm)

OR

Q6) a) Write a complete part program using G and M codes for the job shown in fig. 3. Assume suitable speed and feed for machining. [12]

- **Billet size** - Diameter: 60 mm and Length: 90 mm.
- **Thread:** Major Diameter, $D_0 = 20$ mm, Minor Diameter, $D_c = 17$ mm and Pitch: 2.5mm, Groove: Width = 5 mm and depth = 2.5 mm.

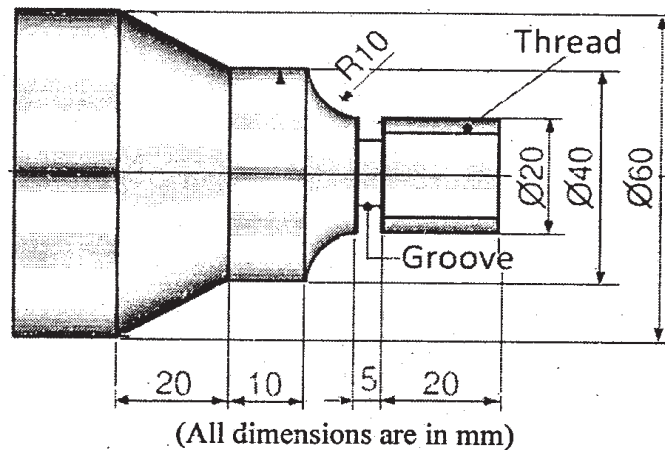

Fig.3

b) Explain with neat sketch: Machine Origin, Work Piece Origin and Program Origin. State importance of each. (*Origin may be treated as Reference*) [6]

Q7) a) Write steps in **Laminated Object Manufacturing** with neat Sketch. State its applications. [8]

b) Write steps in **Selective Laser Sintering method** with neat sketch. State its advantages. [8]

OR

Q8) a) Write steps in **Stereo lithography process** with neat sketch. State its limitations. [8]

b) Explain different steps in **Rapid Prototyping (RP) Systems**. Also write a short note on Rapid Tooling. [8]

- Q9)** a) Define Industrial Robot. Explain 04 Parameters in robot selection. [8]
- b) How does FMS ensure *Flexibility* in Manufacturing? Explain elements of FMS. [8]

OR

- Q10)**a) Explain the term “*Work Volume or Work Envelope*” of Robot. List various work volumes. [8]
- Explain *Cylindrical Robot Work Envelope*.
- b) What is Group Technology (GT)? Discuss machine cell design in GT? [8]

